

Citroën C3 12/2016 >> 07/2020
Citroën C3 08/2020 >>

Partnr.: PE-065-B1U

- Fitting instructions electric wiring kit tow bar with 12-N socket up to DIN/ISO Norm 1724.
- We would expressly point out that assembly not carried out properly by a competent installer will result in cancellation of any right to damage compensation, in particular those arising by virtue of the product liability act.
- Contents of these kits and their fitting manuals are subject to alteration without notice, please ensure that these instructions are read and fully understood before commencing installation.
- Do not overload circuits; the maximum loads per connection are detailed in this manual.
- Attention! Before Installation, please read this manual carefully and inform your customer to consult the vehicle owners manual to check for any vehicle modifications required before towing.
- In the event of functional problems, troubleshooting must be limited to about 0.5 hours, contact the technical support:
ukts@ecs-electronics.com / 07440 202 052.



Part list

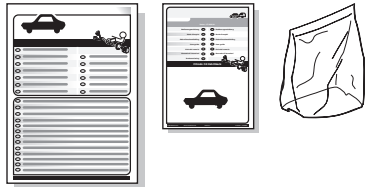
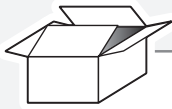

Optional UN-243-YZ
Reverse lamp pre-wire extension

Page 16

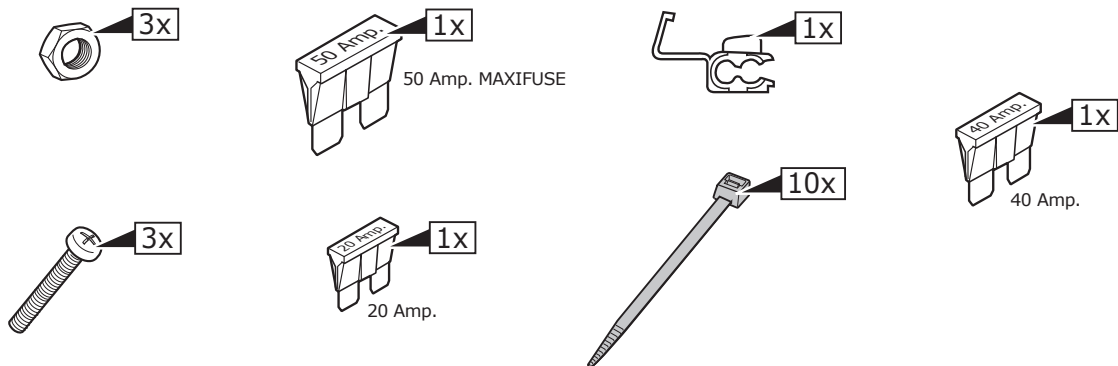
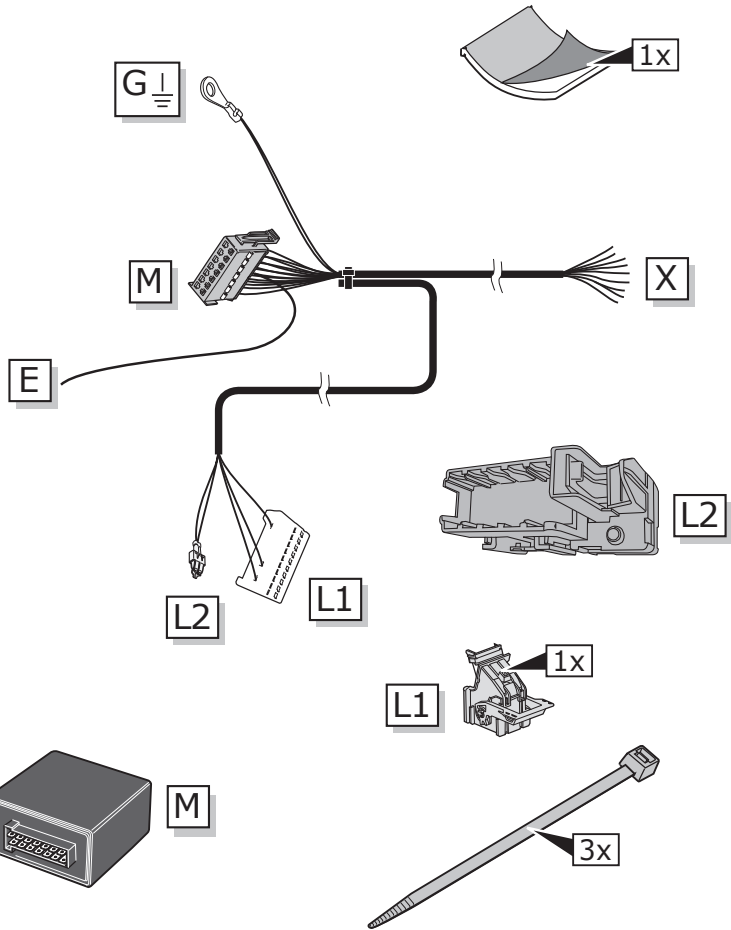
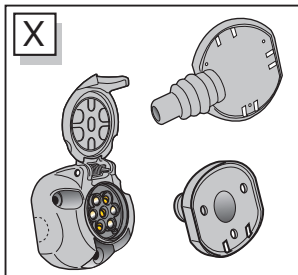

INFO

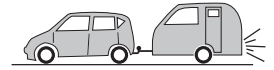
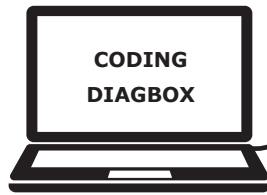
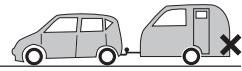

Code vehicle for lighting functions

ROUTING

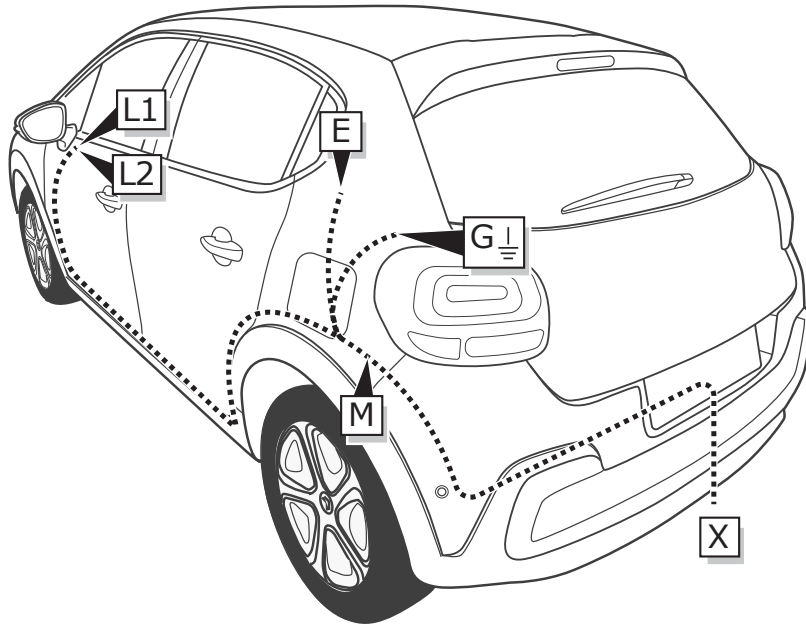

1

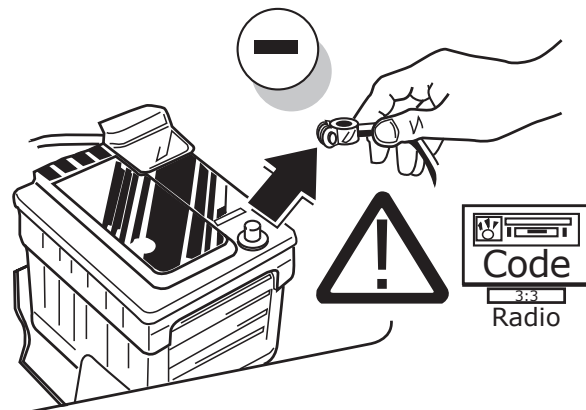

2

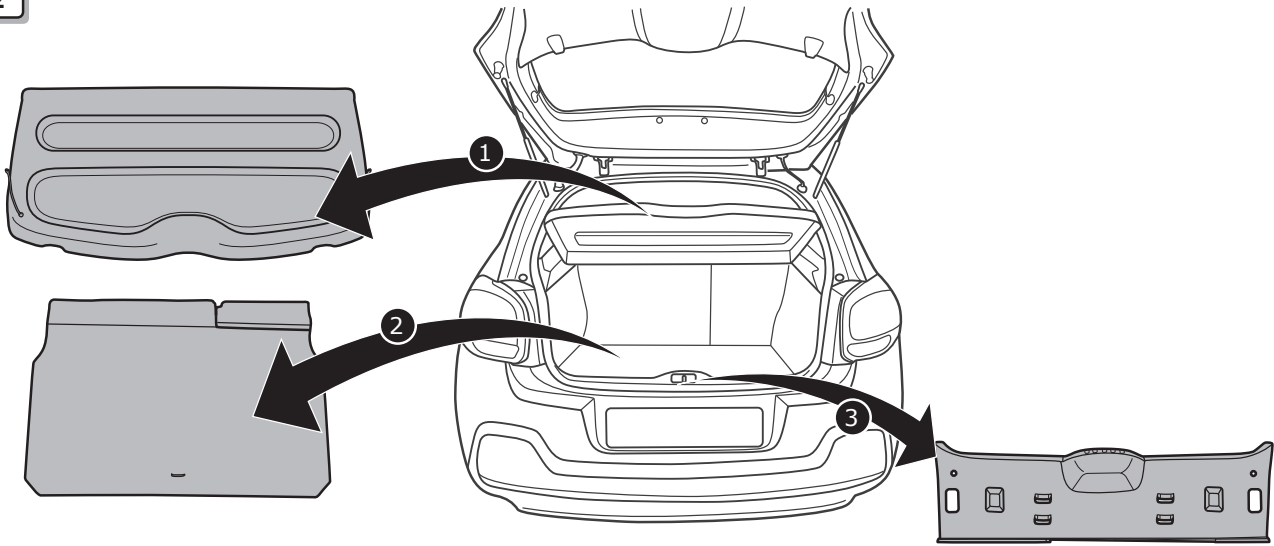

3

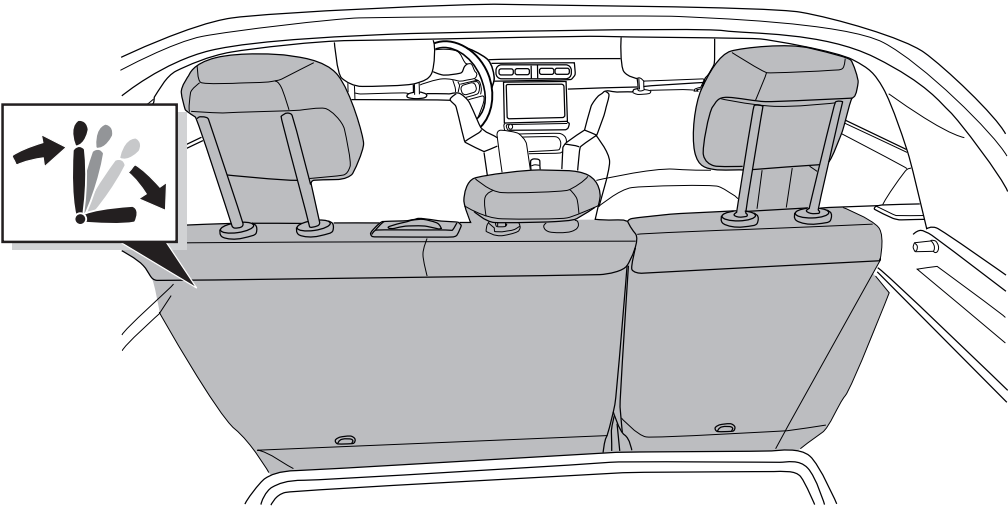

4

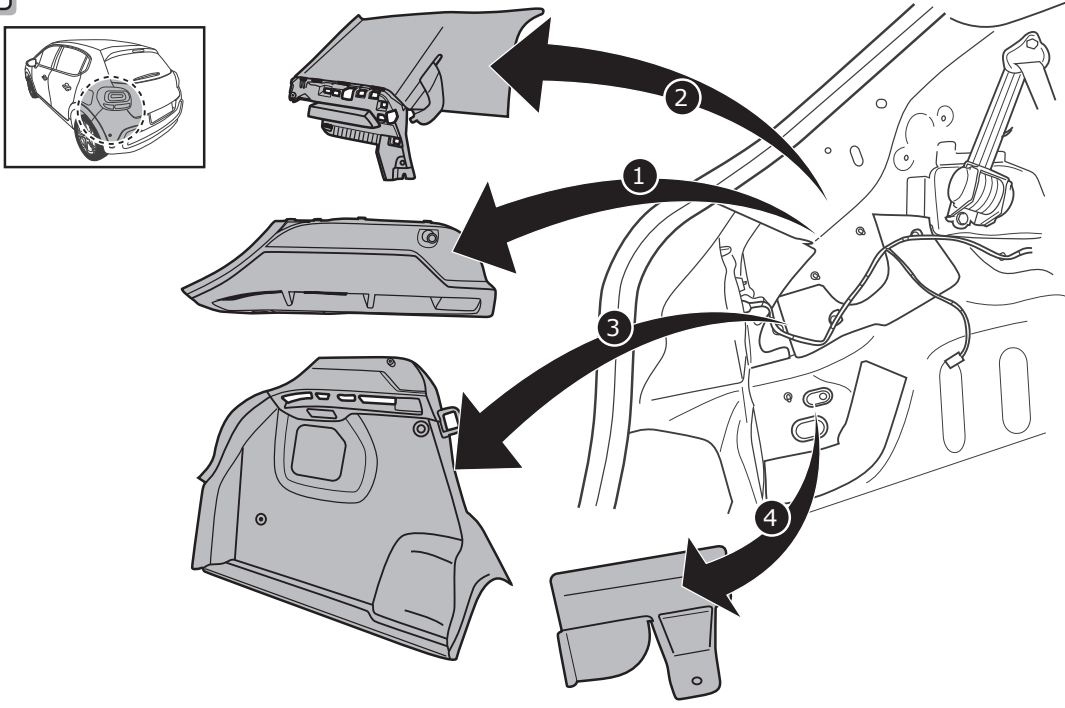

5

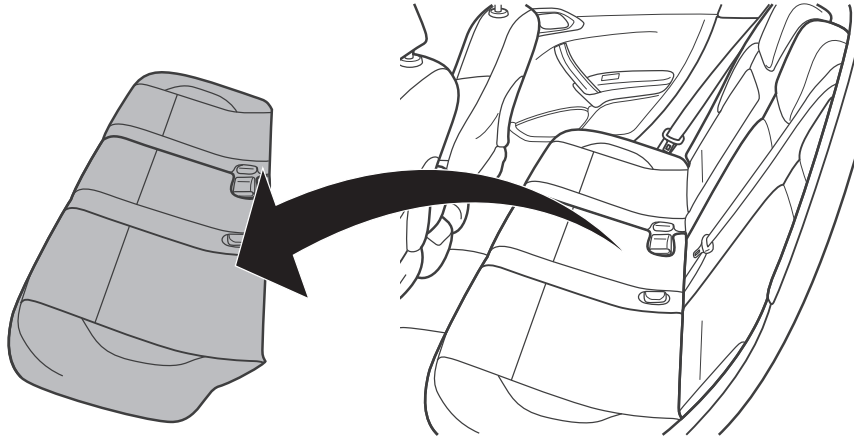
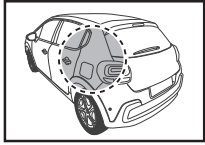

6

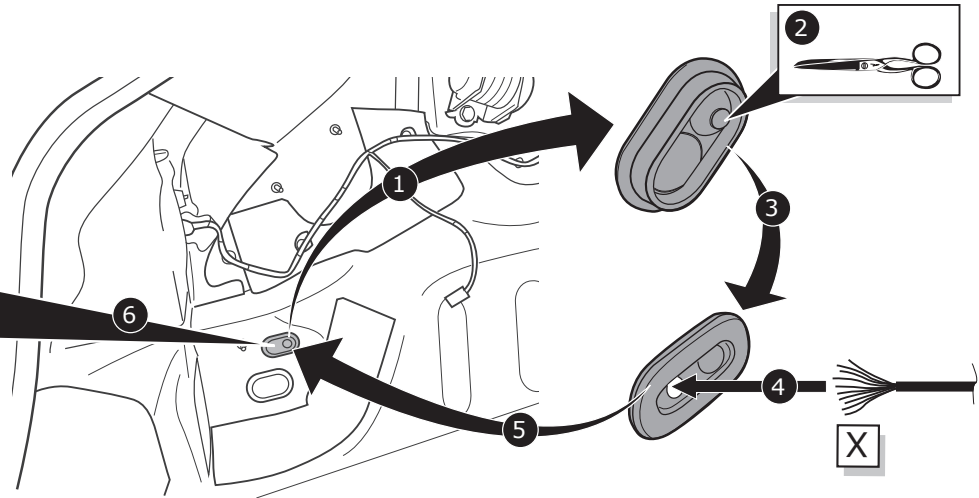
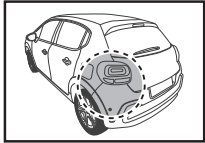

A

Option 1

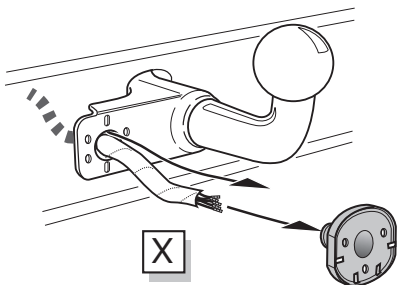

Option 2

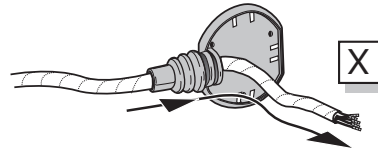

Option 3

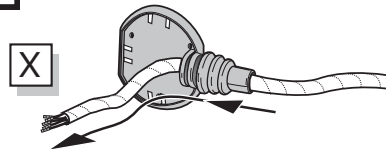

INFO

SOCKET CONNECTION



Page 15

B

Option 1

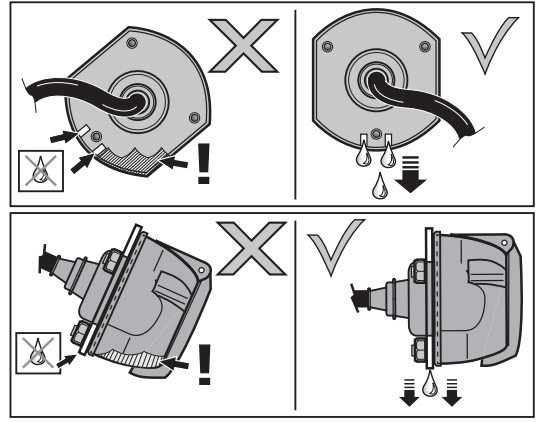
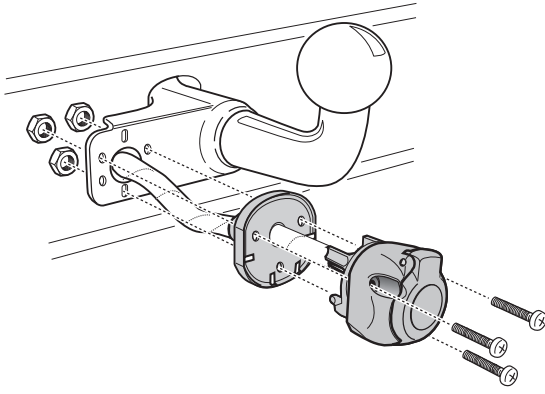
**C**

Option 2

1

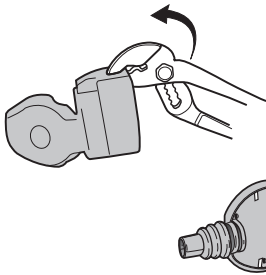

2

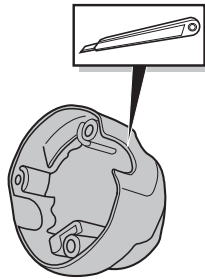

3

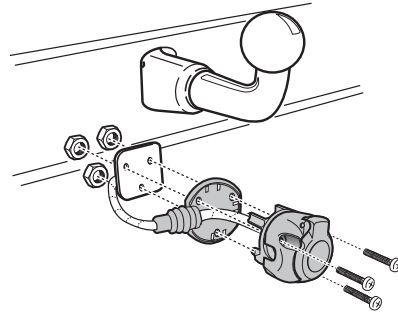
**D**

Option 3

1

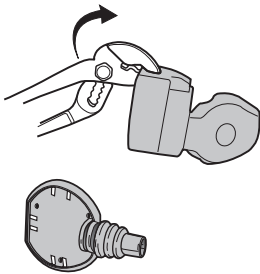

2

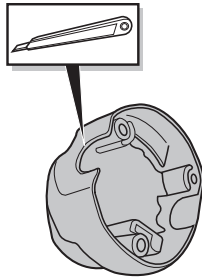

3

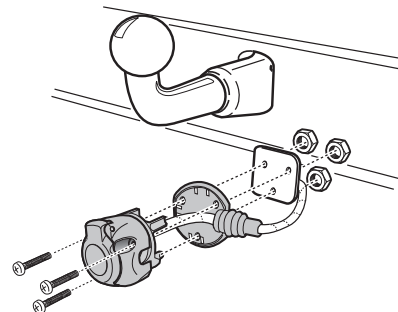
**7**

1

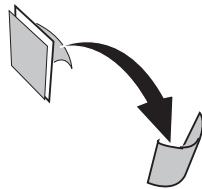
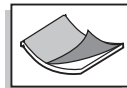
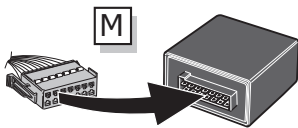

2

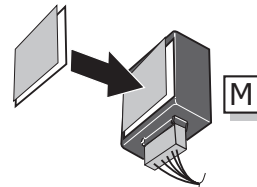

3

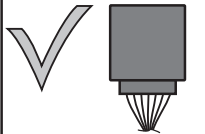

4

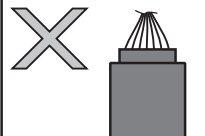
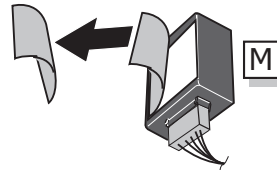

7

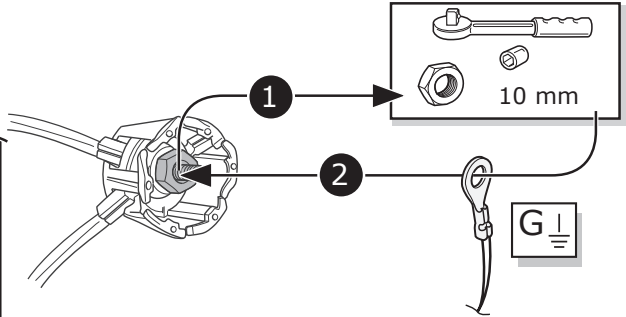
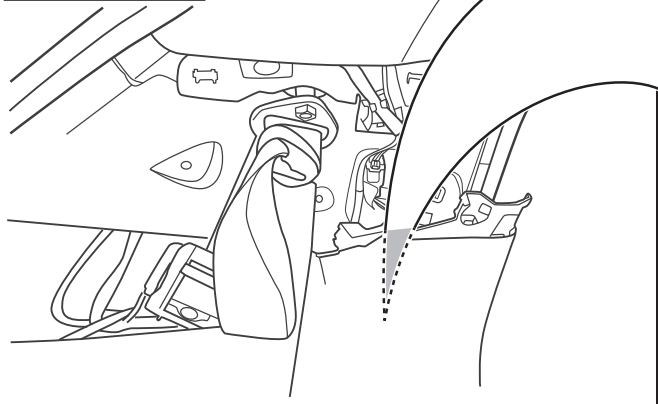
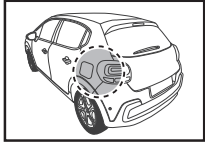

8

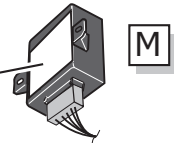
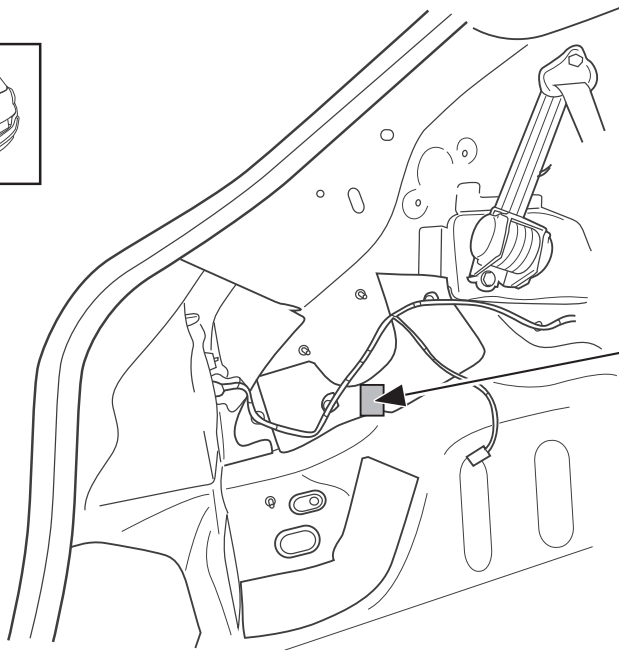
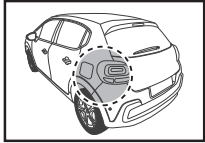

9

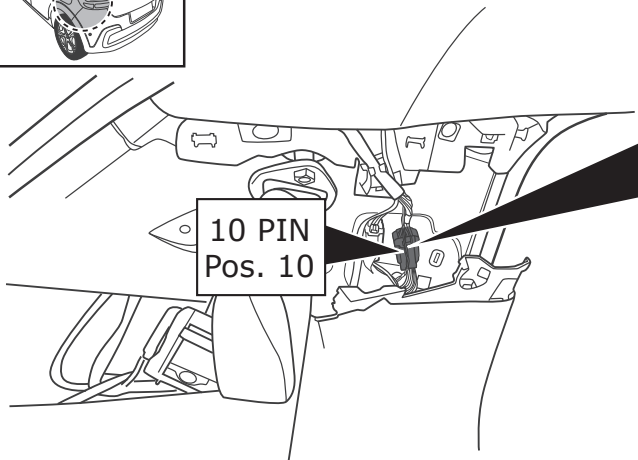
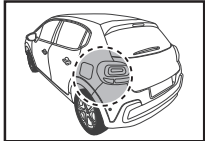

10 PIN
Pos. 10

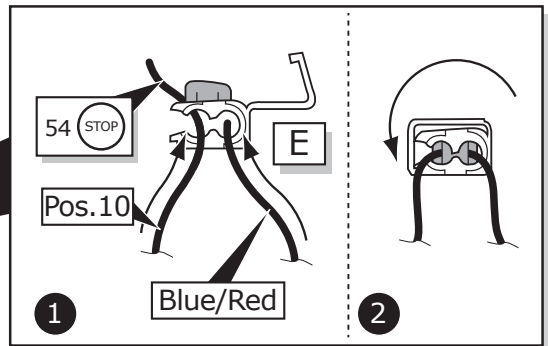

11

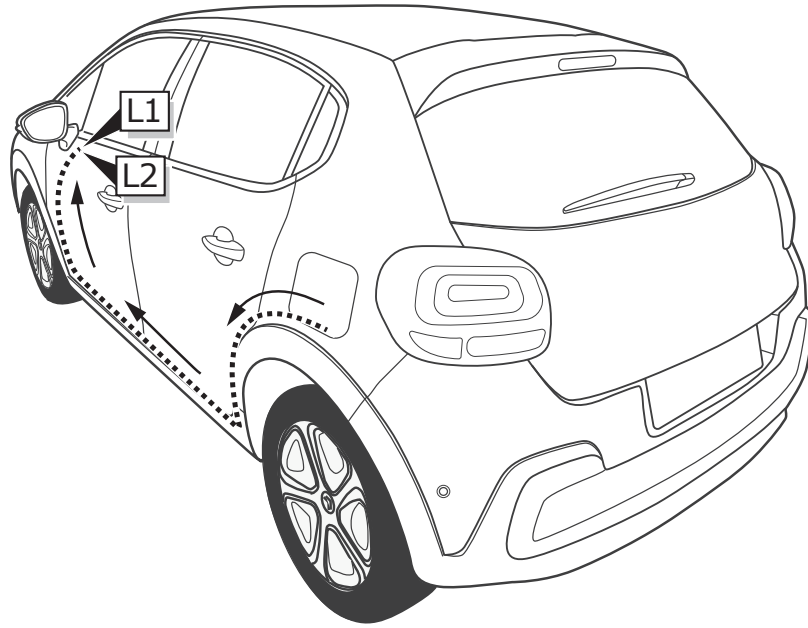

12

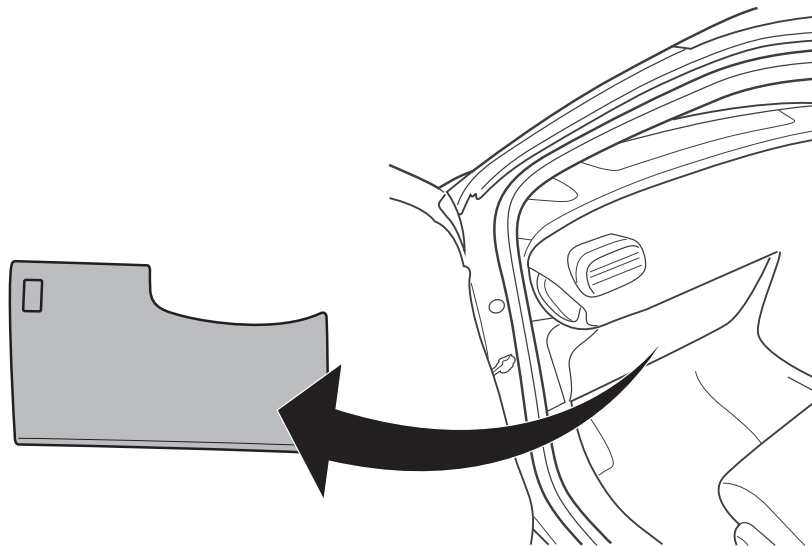
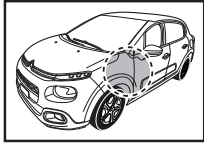

13

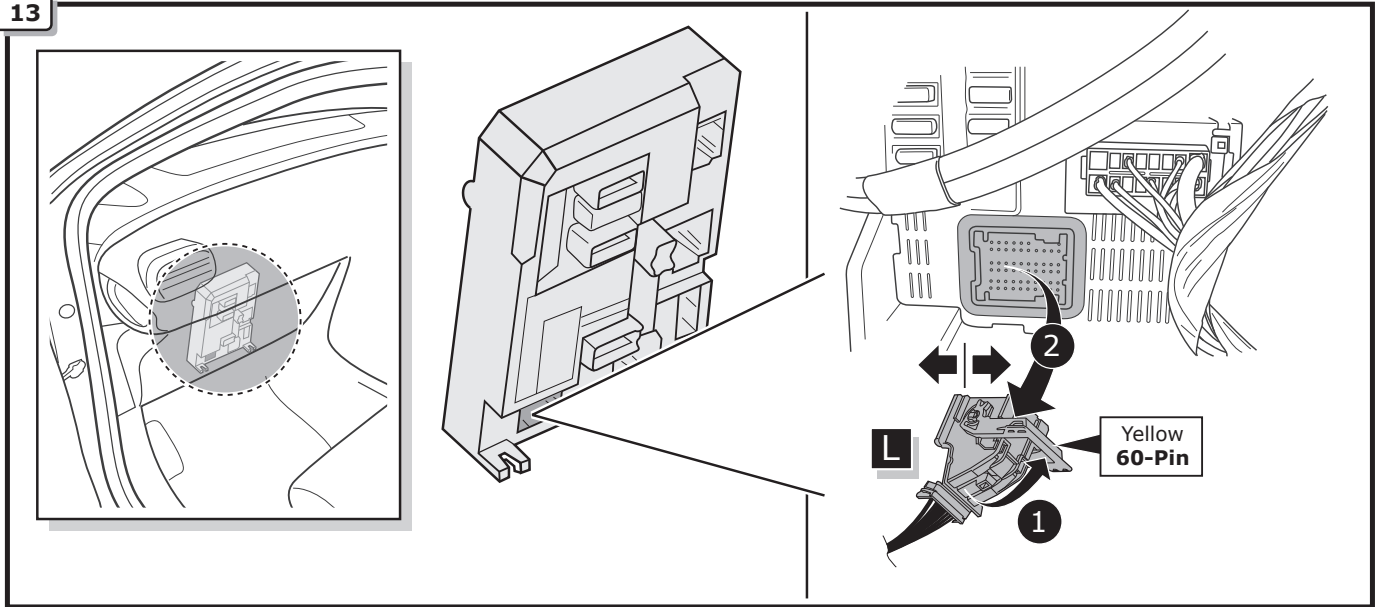

14

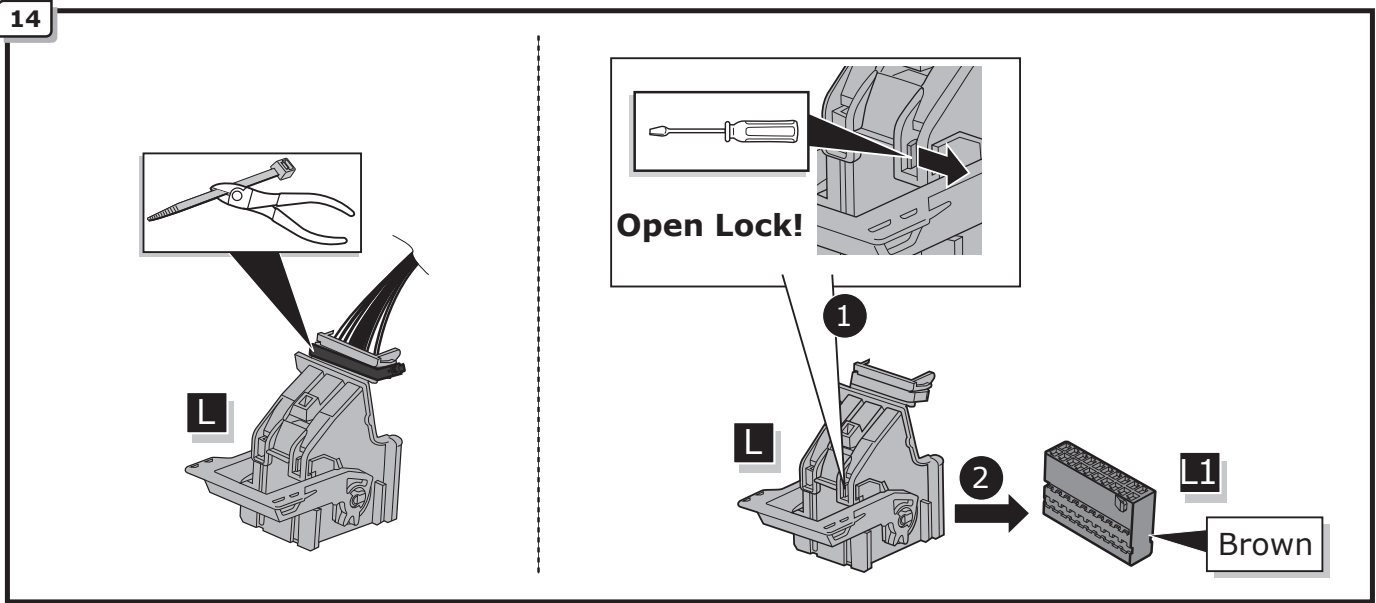

15

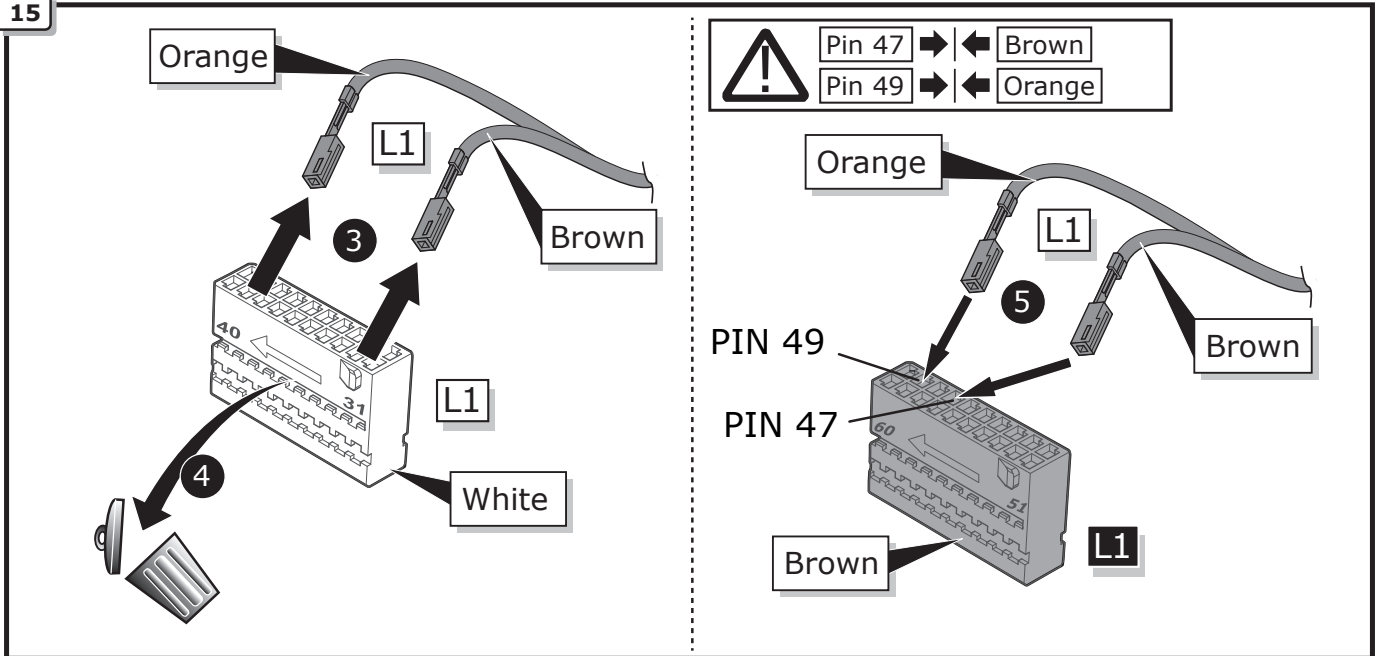

16

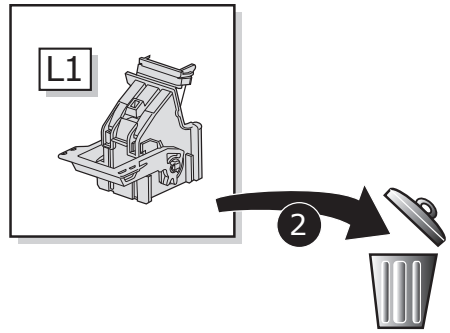
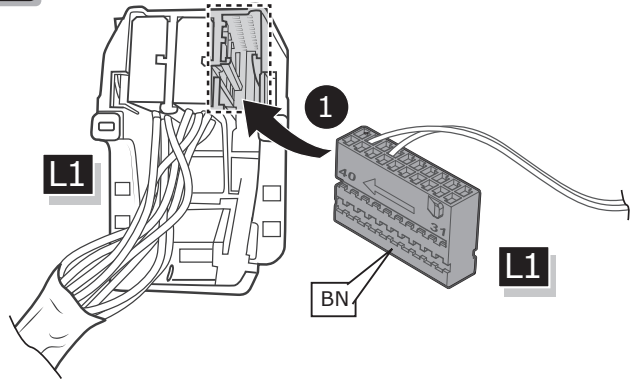

17

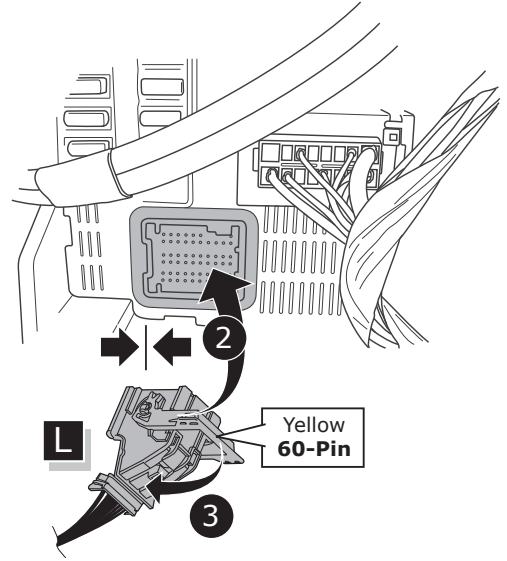
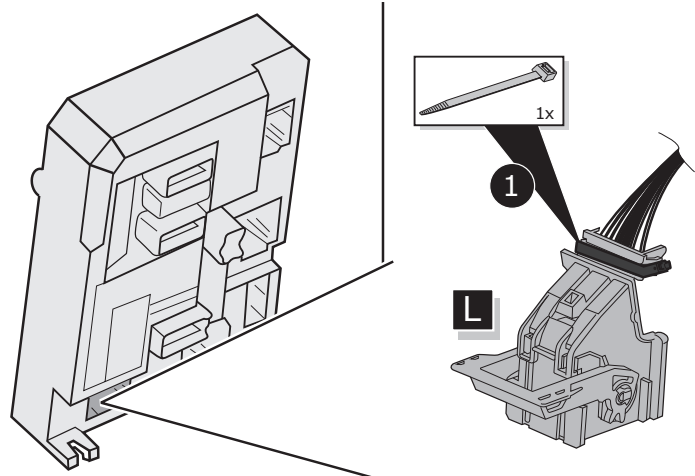

18A

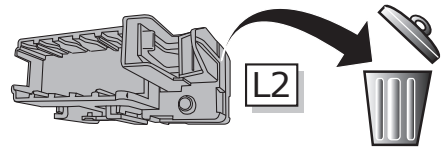
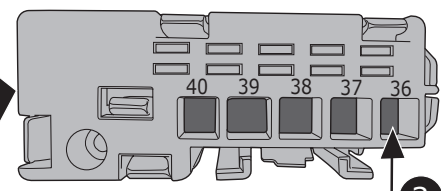
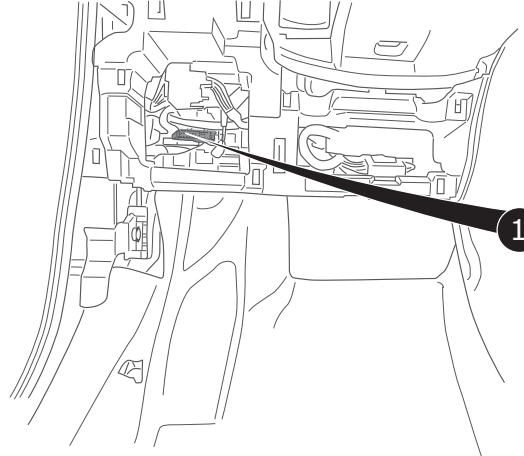
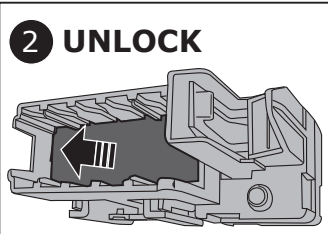
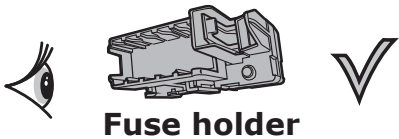

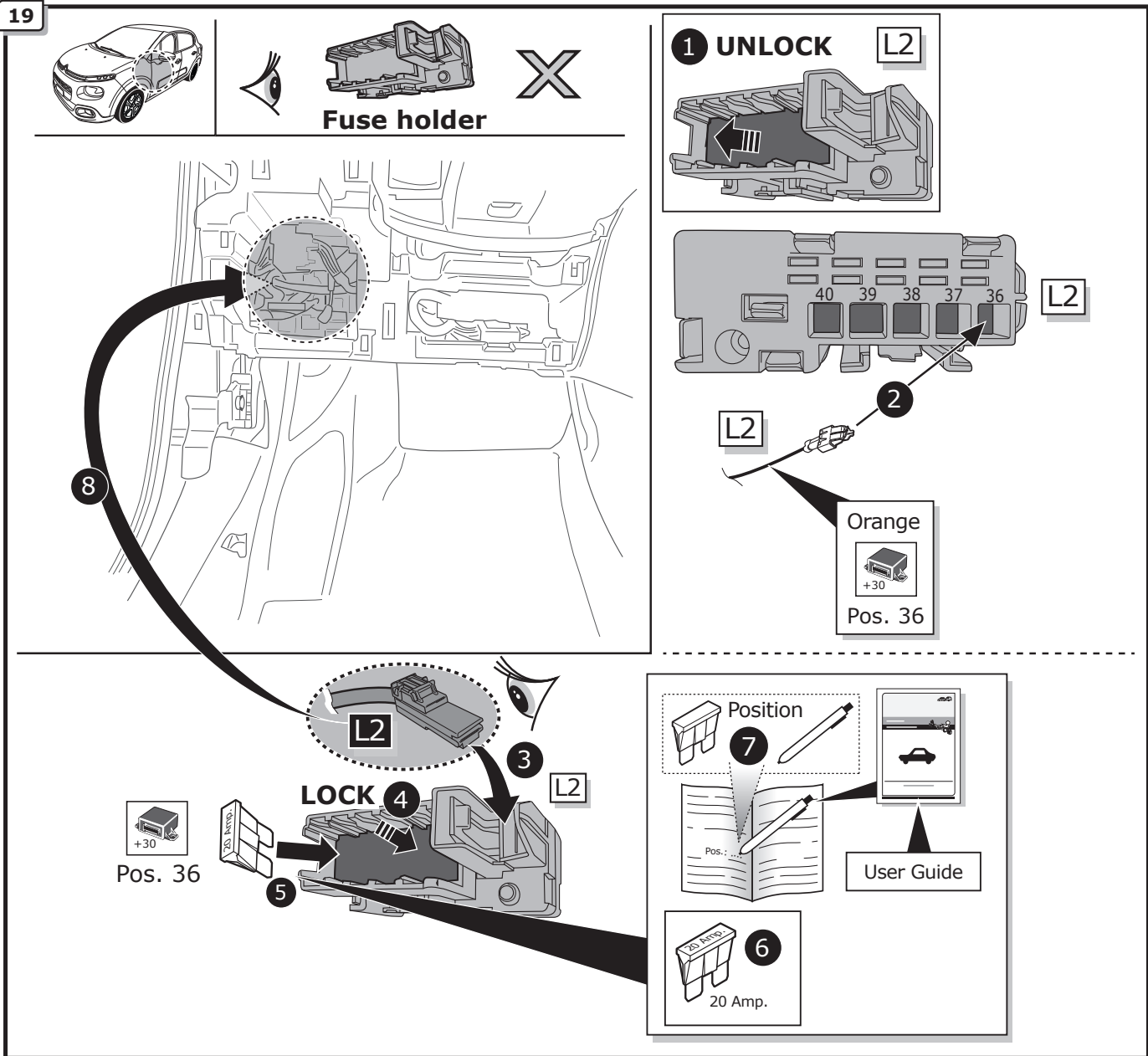
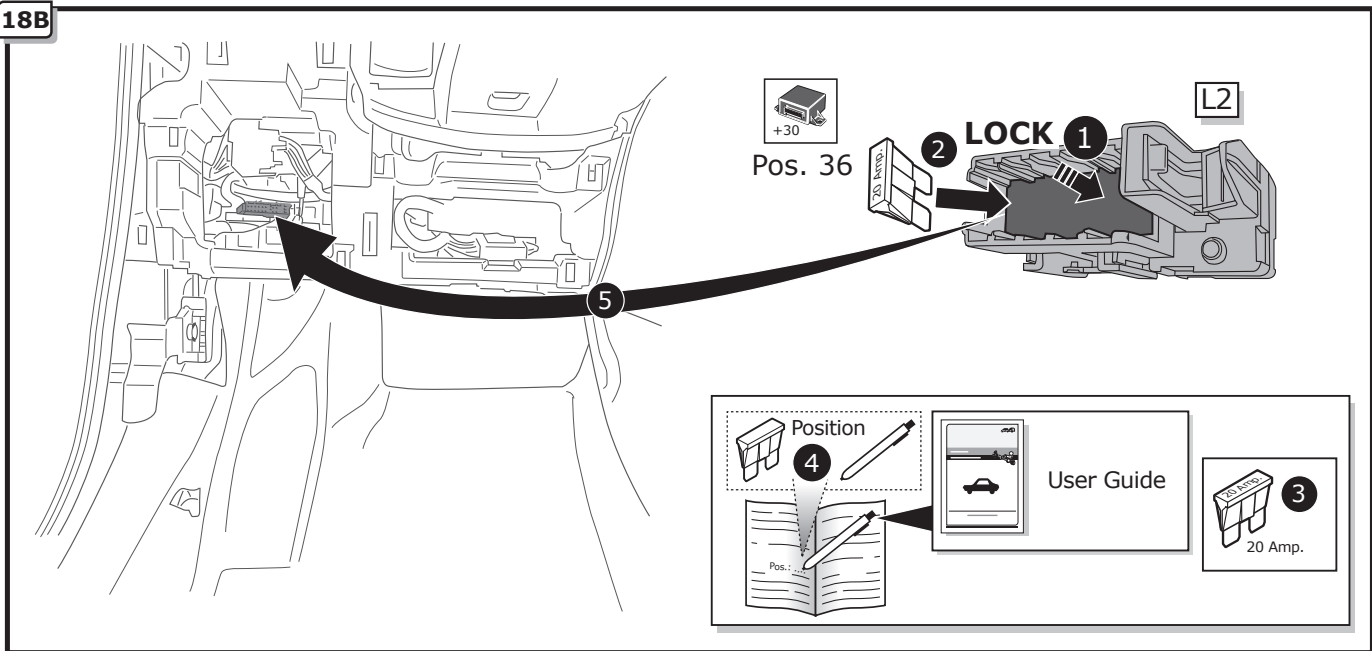

20

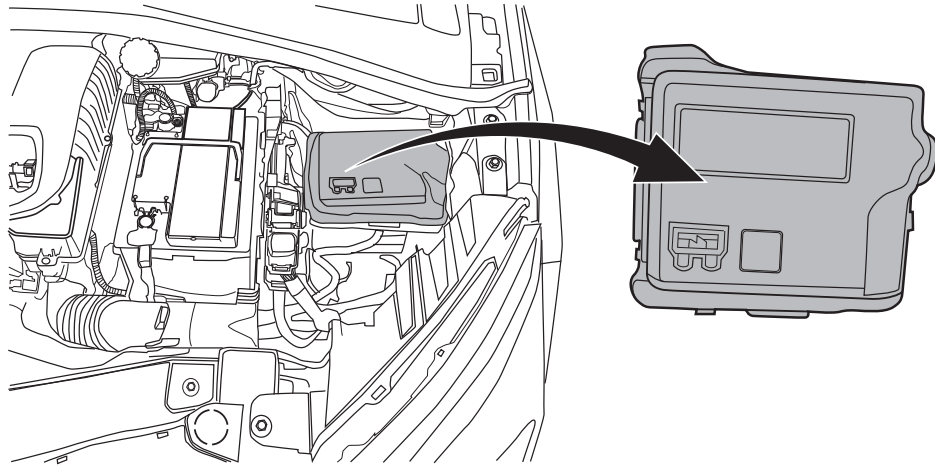
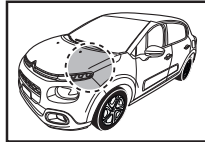

21

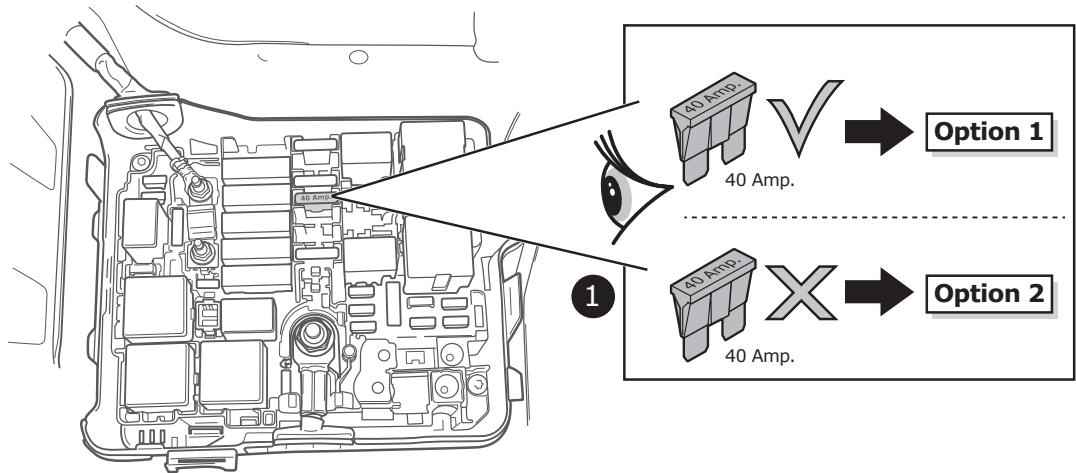
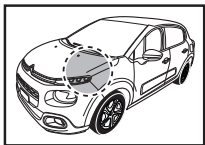

Option 1

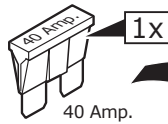
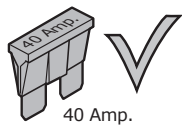

Option 2

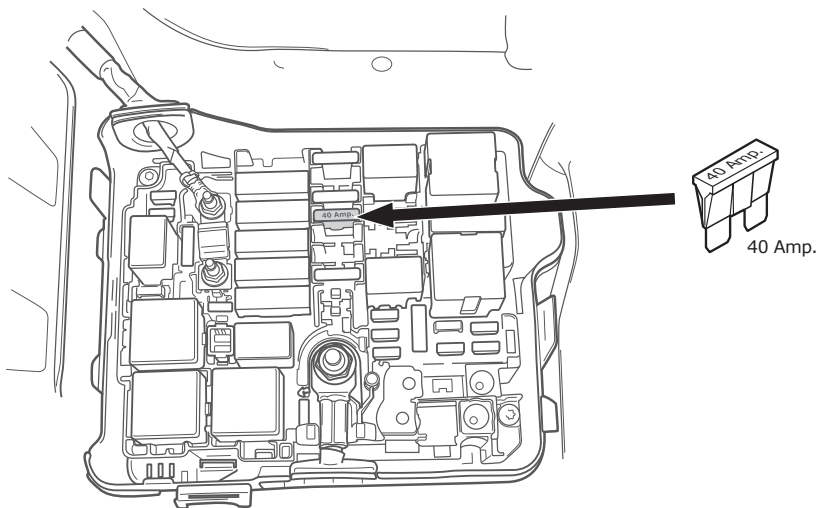
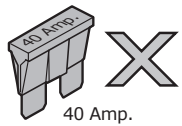

22

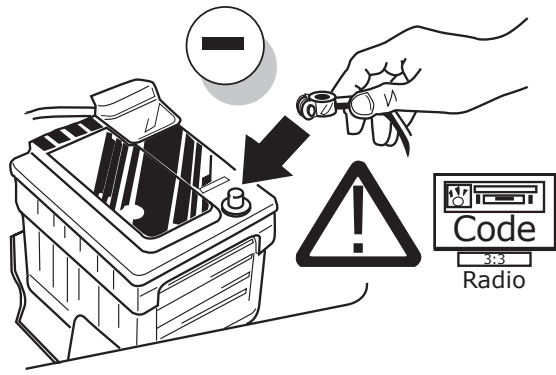

23

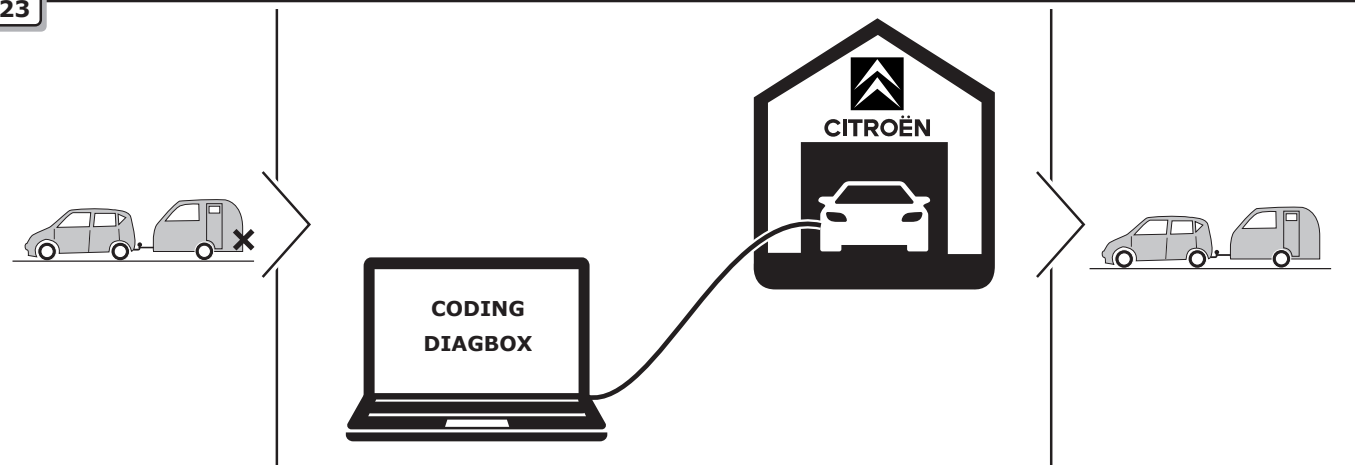

The activation of the trailer functions has to be carried out using the **CITROËN DIAGBOX** as follows:

- choose vehicle
- delivery
- equipment
- trailer control unit (BSR)
- installation of equipment

24

Functional test

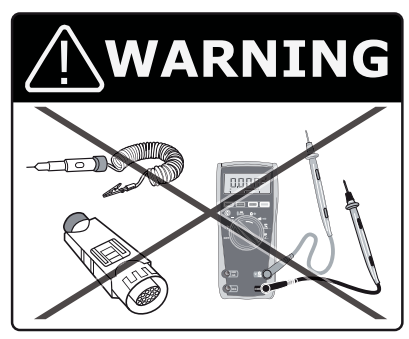
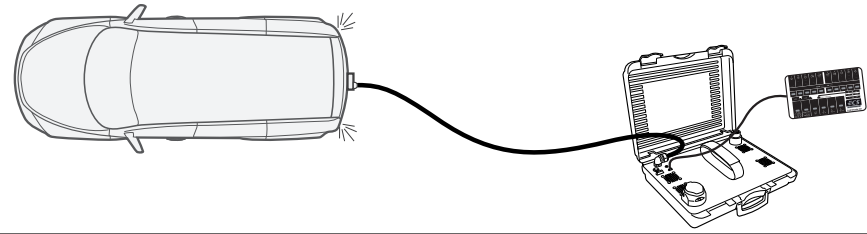
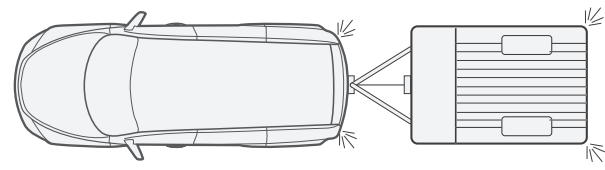
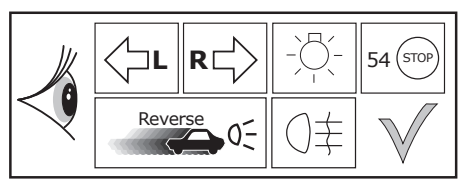

LIGHTMATE

ECS part no.
LIGHTMATE II
LIGHTMATE III

25

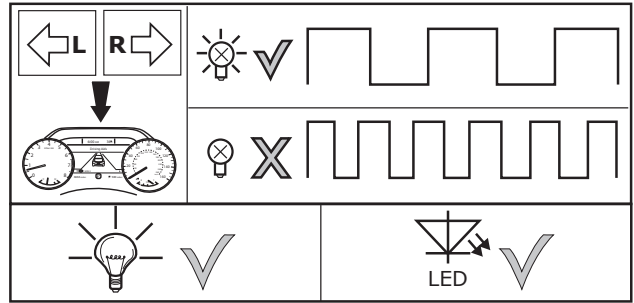
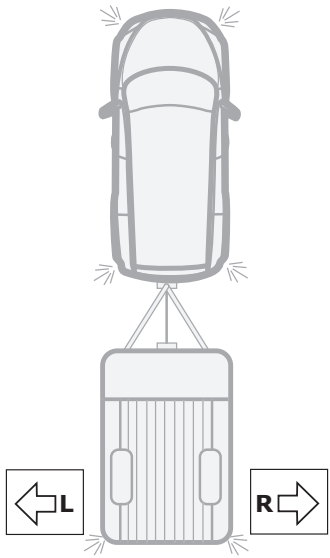

26

Optional

Adapter socket

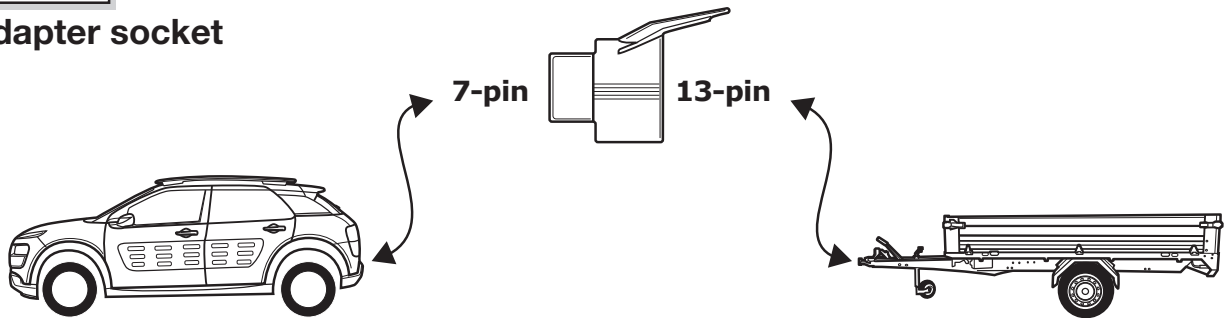

27

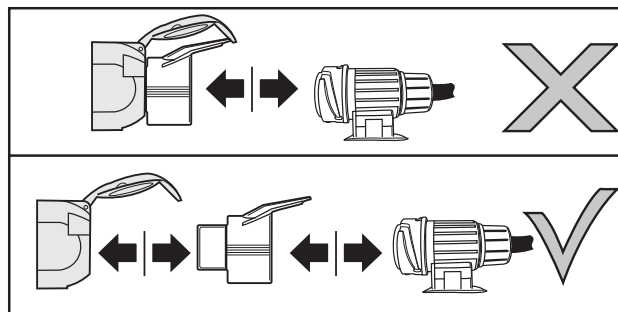
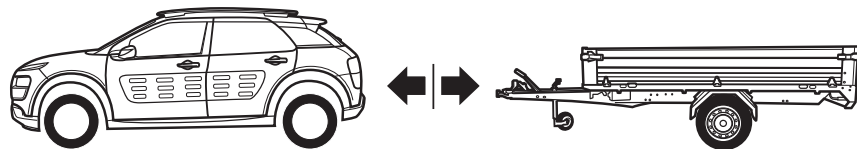

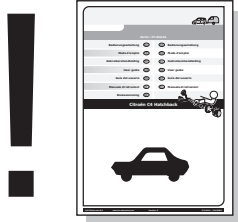
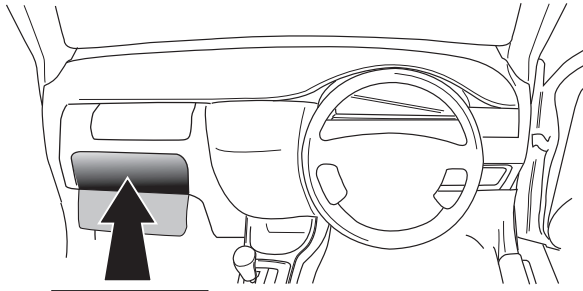

User guide



INFO

SOCKET CONNECTION

DIN/ISO 1724							
	1/L	2	3/31	4/R	5/58-R	6/54	7/58-L
Pmax	21W	21W		21W	52W	3x21W	52W
Colour	Yellow	Blue	White	Green	Brown	Red	Black

UN-243-YZ Reverse lamp pre-wire extension

⚠ MAX = 21W

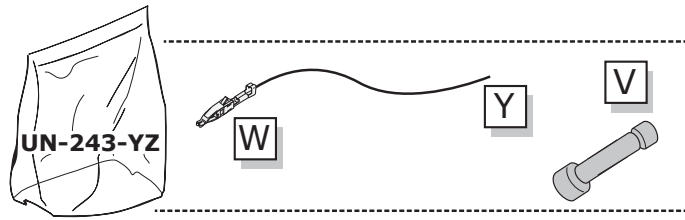

A

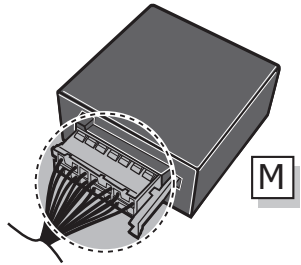

1

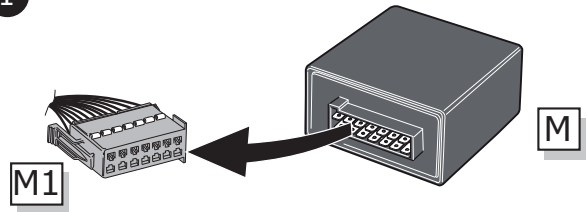

2

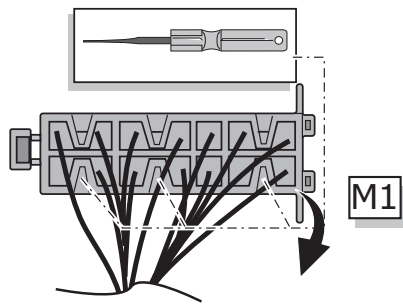

3

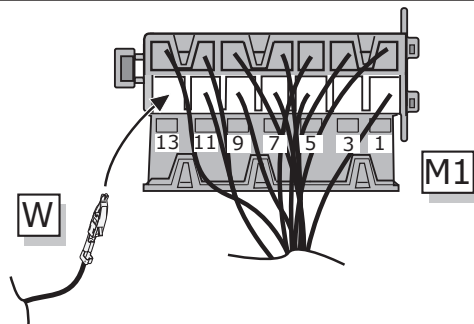

4

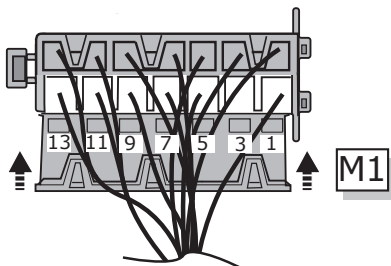

5

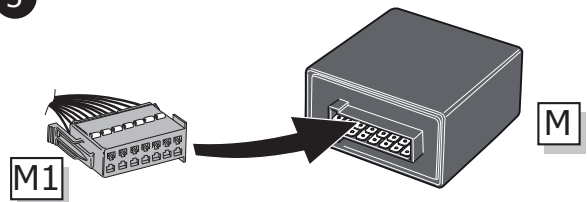

B

⚠ MAX = 21W

